

Applications:

Automatic clamping of dies

- on press rams
- on hold-down devices
- at max. ambient temperatures of 70°C

Function:

The rotation of the motor is converted into a swinging movement and a stroke of the tie rod by the flexspine gear, the lead screw and the control pin.

The tie rod swings out by max. 15°.

The clamping force is transmitted to the clamping point in the axial direction of the tie rod.

The clamping force and the clamping and unclamping positions are monitored by inductive proximity switches.

The clamping force is maintained by mechanical self-locking.

Special features:

- ◆ clamping stroke up to 13 mm, which means high adaptability to varying heights of clamping edges
- ◆ position monitoring and an automatic cycle ensure high operational reliability
- ◆ central operation of all clamping elements
- ◆ compact design, rugged construction
- ◆ variable length of tie rod
- ◆ resistant to high mechanical loads
- ◆ shock-resistant up to a max. ram acceleration of 12 g
- ◆ suitable for retrofit and for installation in original equipment



Electromechanical swing clamps
mounted on a double-column press.

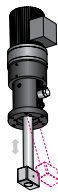

Technical data

Type	8.2653.0101	8.2655.0101	8.2656.0101
Clamping force (kN)	70	120	160
Max. static force (kN)	110	200	300
Clamping speed (mm/s)	3,8	5,7	4,1
Connected motor voltage V/Hz	400/50	400/50	400/50
Motor rating (kW)	0,55	1,1	1,1
Rated motor current (A)	2,1	3,55	3,55
A (mm)	140	160	195
B (mm)	409	522	602
E (mm)	110	140	160
G (mm)	11,0	13,5	13,5
Clamping stroke hs (mm)	11	12	12
Swing stroke (mm)	8,0	10,5	13,0
Installation space l (mm)	85	120	125
K (mm)	102,0	112,5	112,5
M (mm)	40	50	60
N (mm)	90	90	90
O (mm)	40	60	65
U (mm)	28	40	40
W (mm)	130	160	180
X (mm)	42	57	65

Clamping dimension to be quoted in the order

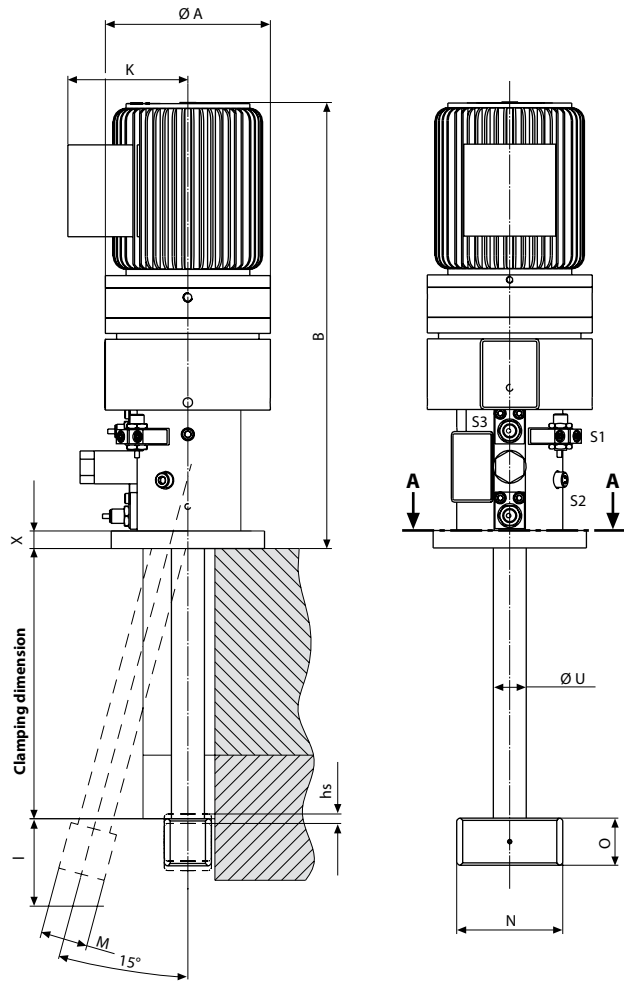

Section A-A

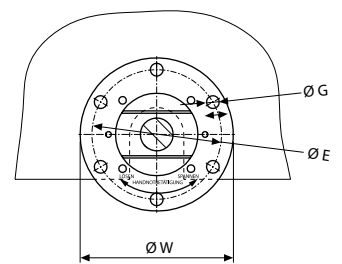

Other clamping dimensions, clamping forces and motor voltages are available on request

Terminal connections

