

EDI™ XPS Foam Board Die Systems

Ensure unsurpassed product quality and performance when you partner with the industry's leader in flat die manufacturing and technology.

Benefits of an EDI Foam Board Die

- **Increase production efficiency** by changing product width and thickness “on-the-fly”
- **Reduce capital investment required** by interfacing easily with existing equipment line layout
- **Minimize scrap product** with optional external edge restrictors, designed to ensure dimensional consistency when the XPS material exits the forming box

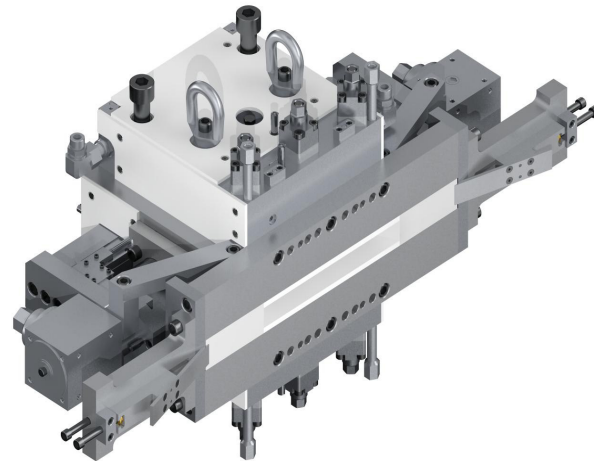

330mm XPS Foam Board Die with Forming Box

Nordson, a leading international supplier of extrusion die technology, provides a die system for extruded polystyrene (XPS) foam board that dramatically reduces downtime for product changeovers, enabling manufacturers to offset much of the loss in productivity caused by switching to a non-ozone depleting blowing agent.



71mm (28") Special Heavy Duty PS Foam Board Die, Purge Block, and Die Cart

Features

- **Easy to adjust components for changing thickness or width**
- **Eliminates downtime when changing product specifications**
- **Special forming box designed for superior board properties**
- **Optional purge block features allows for die maintenance to be carried out while the extruder is temporarily shut down but still full of polymer**